



General Specifications

Link-Belt® 18-Ton (16.33 metric ton)

Hydraulic self-propelled crane

HSP-18

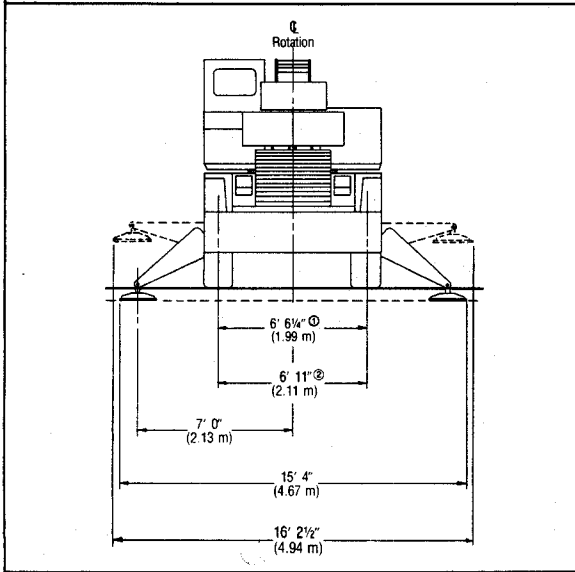
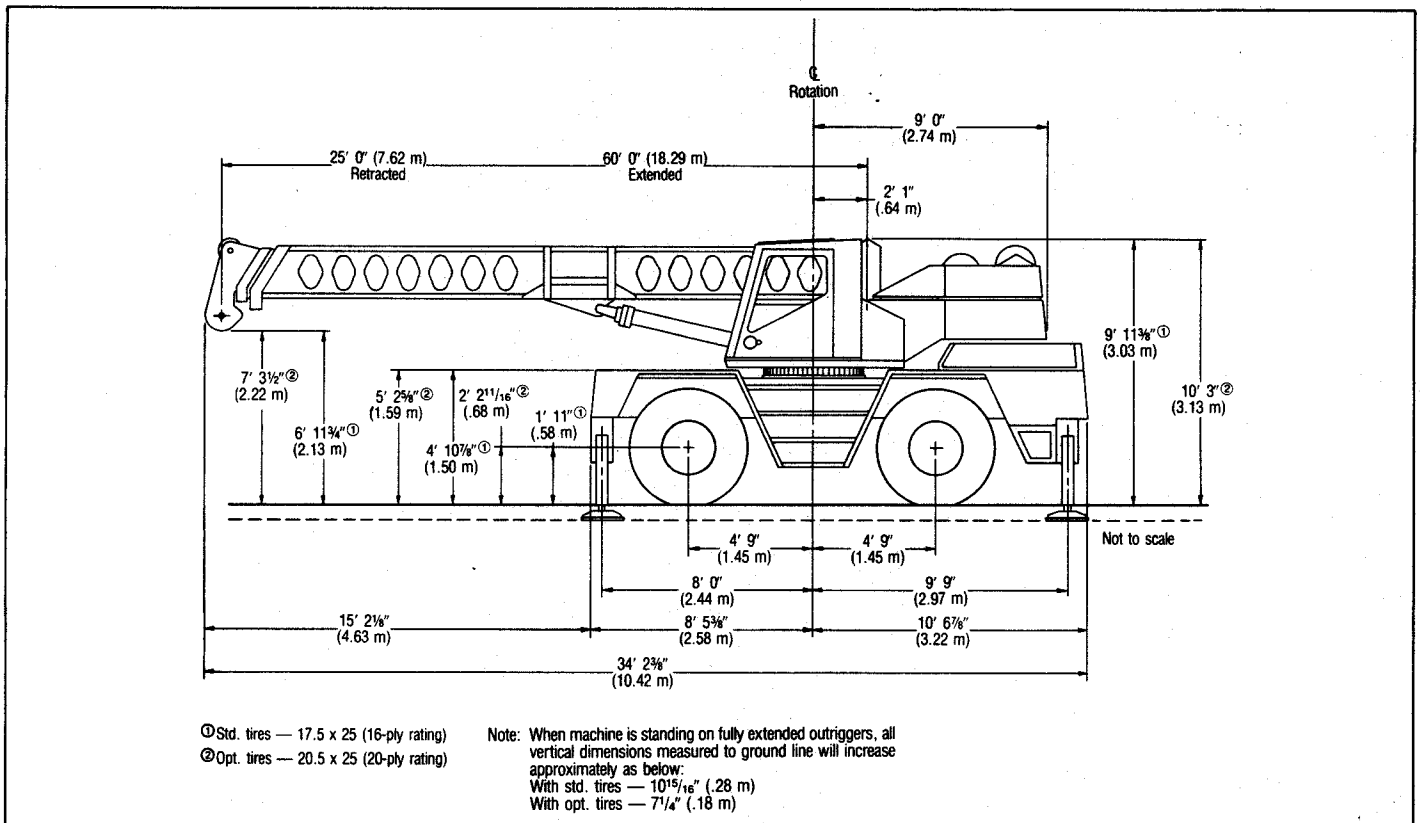

General Dimensions	Feet	Meters
Over-all width ^⓪		
with std. tires	7' 11 ⁷ / ₈ "	2.44
with opt. tires	8' 8 ³ / ₈ "	2.65
Tailswing of counterweight	9' 3 ⁵ / ₈ "	2.84
Minimum ground clearance		
with std. tires	1' 2 ¹ / ₂ "	.37
with opt. tires	1' 6 ¹ / ₄ "	.47
Ground clearance between tires and ground — on outriggers		
with std. tires	6 ³ / ₄ "	.17
with opt. tires	3 ⁷ / ₈ "	.10
Wheelbase	9' 6"	2.90

⓪Outriggers retracted

GENERAL INFORMATION ONLY

Mounting —

Type — FMC self-propelled, 4 x 4 drive, 8'0" (2.44 m) wide, 114" (2.93 m) wheelbase.

Frame — Welded plate; box section construction between outriggers.

Outriggers — Hydraulic pivot type; one pinned at each corner of mounting; 20" x 16" (.51 x .41 m) rectangular steel floats hinged at ends of outriggers. Outriggers individually controlled from operator's cab.

Suspension — 3-point; front axle bolted to frame, rear axle pin connected on bronze bushing to permit axle oscillation. Manual axle lockouts provide stable 4-point suspension for 'on tires' and 'pick and carry' lifting capacity.

Axles — Rockwell Std. PSM-824 drive/steer axles; 78¼" (1.99 m) track with standard tires, 83" (2.11 m) with optional tires.

Wheels and Tires — Planetary drives at wheel. Std. tire — 17.5 x 25 (16-ply); optional — 20.5 x 25 (20-ply rating).

Brakes — Rockwell Std. 4-wheel air over hydraulic service brakes, with spring applied, air released parking/emergency brake on front axle drive line.

Steering — Full power hydraulic; pump mounted directly to transmission. 2-wheel, 4-wheel and 'crab' steering; 14" (.36 m) dia. steering wheel.

Turning Radius — measured to center line of outside tire — std. tires; 25'8" (7.86 m) for two wheel steer; 15'8" (4.82 m) for 4-wheel steer. Optional tires; 25'10" (7.91 m) for 2-wheel steer; 15'10" (4.85 m) for 4-wheel steer.

Axle Loadings — Basic boom retracted over front of mounting, with std. counterweight, optional fender package on machine and hook block.

Engine — GM 4-53 diesel; 4 cylinder, 2 cycle, 3⅞" (98.43 mm) bore, 4½" (114.30 mm) stroke, 212 cu. in. (3 478 cm³) displacement. Max. brake h.p. — 136 @ 2,800 r.p.m. governed load speed. Peak torque — 282 ft. lbs. (39.0 kgm) @ 1,800 r.p.m. Engine equipped with Donaldson dry type air cleaner and blower fan. Crankcase capacity — 3.5 gallons (13.25 liters).

Air Compressor — 12 c.f.m. (.34 m³/min); Bendix-Westinghouse Tu-Flo 400.

Fuel tank — 62 gallons (13.25 liters) capacity.

Transmission — Allison TT-2221-1 powershift with TT-270 twin-turbine torque converter; 4 speeds forward, 2 reverse.

Travel Speeds, Gradeabilities and maximum tractive efforts — (see charts)

Standard Tires					
Transmission Range	Maximum Speed		Maximum Gradeability ^①	Maximum Tractive Effort @ Stall	
	M.p.h.	Km/h		Pounds	Kilograms
Hi	24	38.6	22.6%	9,120	4 137
Low	6	9.7	73.5	37,800	17 146
Rev	9	14.5	73.5	27,920	12 665

Optional Tires					
Transmission Range	Maximum Speed		Maximum Gradeability ^①	Maximum Tractive Effort @ Stall	
	M.p.h.	Km/h		Pounds	Kilograms
Hi	27	43.4	19.1%	7,845	3 558
Low	7.5	12.1	73.5	32,600	14 787
Rev	10.4	16.7	73.5	24,000	10 886

^①Limited by surface conditions.

Hydraulic Pump Drive — Four section gear-type hydraulic pump mounted directly on extended shaft of transmission and driven by straight mechanical drive from the engine, supplies hydraulic oil flow for crane upper functions.

Hydraulic Sump Tank — FMC; fabricated with internal baffles for strength, deaeration, and cooling of oil. Equipped with 3 filter elements in tank; tank pressurized to 6 p.s.i. (41.37 kPa); oil capacity 95 gallons (360 liters).

Electrical System — One 12-volt 225 amp/hr battery, 12-volt 42-amp alternator, single sealed beam headlights; tail, directional, back-up, clearance, brake and emergency flasher lights; horn and low air pressure warning buzzer.

Accessories — Standard; skid-resistant finish on deck, cab access ladder, and storage compartment. Optional; fenders with lights as described under electrical system, towing shackles, spare tire and rim, cold weather starting accessories and lifting lugs.

Rotating Joint — FMC 10-way rotation joint provides passage of hydraulic oil, air and electrical lines between mounting and revolving upperstructure.

Revolving Upperstructure —

Frame — All-welded, line bored; provides boom mounting base, wire rope drum supporting frame, and attachment points for boomhoist cylinders.

Turntable Bearing — Inner race bolted to upper; outer race, with integral external swing gear, bolted to mounting deck.

Hydraulic System — The four section pump operating at 2,800 r.p.m. produces flow ratings of 50 g.p.m. (189.25 liters/min.) @ 2,800 p.s.i. (19 306 kPa) for boomhoist, rear main and auxiliary front drums; 21 g.p.m. (74.49 liters/min.) @ 2,500 p.s.i. (17 238 kPa) for swing and boom tip telescope; 21 g.p.m. (74.49 liters/min.) @ 2,500 p.s.i. (17 238 kPa) for outriggers and boom middle section telescope, and 16 g.p.m. (60.56 liters/min.) @ 2,500 p.s.i. (17 238 kPa) for power steering.

Machine	Gross Weight ^①		Upper Facing Front ^②				Upper Facing Rear ^②			
	Lbs.	kg.	Front Axle		Rear Axle		Front Axle		Rear Axle	
			Lbs.	kg.	Lbs.	kg.	Lbs.	kg.	Lbs.	kg.
um	42,484	19 271	21,133	9 586	21,351	9 685	15,090	6 845	27,394	12 426
um	42,539	19 296	21,111	9 576	21,428	9 720	15,167	6 880	27,372	12 416

^① Hook block at bumper.

^② Hook block at boom point.



Control System — Swing, boom telescope, hoist motors and boomhoist functions controlled by levers in cab directly in front of operator. Push-pull type cables transmit force from control lever to the main hydraulic control valves. Foot pedals also provided for control of boomhoist, air throttle, service and swing brakes. Electrical switches control hydraulic outriggers, 2-wheel, 4-wheel, or 'crab' steering.

Swing System — Consists of a bi-directional hydraulic motor, mounted to speed reducers, vertical swing shaft and swing pinion; 360° rotation right or left.

Swing Speed — 3.0 r.p.m.

Swing Brake — Manually applied and released; two-shoe brake and brake drum mounted on speed reducer input shaft.

Swing Lock — Standard; manually controlled, two-position, pin type swing lock permits locking upper in travel position with boom centered directly over either end of machine. 360° house lock permits upper to be locked in any position — optional.



Single Speed Load Hoist System — Standard; rear main hoist drum. Driven by bi-directional gear-type hydraulic motor through planetary speed reduction unit. Automatic spring, applied, hydraulically released disc drum brake integrally mounted to gear-type hydraulic motor. Brake automatically applied when load hoist control lever is returned to neutral position. The control lever actuates the main control valve in the load hoist hydraulic circuit and gives smooth, precise power control of load hoisting/lowering. Optional; auxiliary front hoist drum, driven in same manner as rear drum.

Two-Speed Load Hoist System — Optional for rear main hoist drum only; hoist drum is direct driven by bi-directional, tandem gear-type hydraulic motor. High speed is obtained by depressing a button on swing lever which actuates an electrical solenoid valve that diverts the oil through only one section of the hydraulic motor. For power load lowering, a holding valve restricts the outlet side of the hydraulic motor and requiring positive hydraulic pressure to reverse the motor and power the load down. An automatic, spring applied, hydraulically released brake is mounted on the hydraulic motor shaft.



Drums Wire Rope Capacity — Front and Rear; 529' (161.24 m) of $\frac{9}{16}$ " (14.31 mm) rope.

Drum Rotation Indicators — Standard with either load hoist system.

Operator's Cab — Offset; key locked door on sliding track with automatic lock to hold door open. Cab insulated from vibration by rubber mounts. Neoprene seal between platform and cab provides insulation from weather and sound. Windows — removable front, sliding rear, fixed side, and hinged rooftop. All windows and door equipped with safety glass panels.

Machinery Cab — Equipped with key locked doors, vented for cooling; hinged top.

Counterweight — Machine with standard main load hoist drum — 4,950# (2 245 kg). Machine with optional auxiliary load hoist drum — 4,100# (1 860 kg).

Attachment —

Boom — 25' - 60' (7.62 - 18.29 m) length. Fabricated box type; machined T-1 steel corner angles, diamond shaped depressions in side plates for lateral stiffness. Three-section power boom with two double-acting (extend/retract) telescoping cylinders. Boom equipped with replaceable, synthetic, rocker support shoes at top and bottom of boom center and tip sections, and at sides of base and center boom sections. Bumper pads at top side of base and center sections minimize boom sections springing upward due to quick load release.

Deflector Roller — One load hoist wire rope deflector roller, mounted on anti-friction bearings, mounted on lower top side of boom base section.

Boom Top Section — Hammerhead design, can be equipped to handle up to 8 parts of wire rope with 3 or 4 head sheaves and dead end link. Two idler sheaves permit reeving of both drums. All sheaves $10\frac{5}{8}$ " (.27 m) root dia. mounted on anti-friction bearings.

Auxiliary Lifting Sheave — Optional; single $10\frac{5}{8}$ " (.27 m) root diameter sheave, mounted on anti-friction bearings; for reeving one or two parts of load hoist wire rope off main rear, or optional auxiliary, front drum. Sheave mounting bracket bolted to boom head — does not interfere with stowing of fly or use of main boom head sheaves for multiple rope reeving.

Boom Length Indicator — Optional.

Boom Angle Indicator — Standard.

Hook Block — Optional.

Optional Accessories — Load moment indicator, with function kickout; anti-two block, boom working light package, cab mounted working light package.

Fly — Optional; 20' (6.10 m) long, one-piece lattice type; mounted in-line with boom.

Fly Point Sheave — Single $10\frac{5}{8}$ " (.27 m) root dia. sheave mounted on anti-friction bearings.

Weighted Ball/Swivel Hook — Optional.

Wire Rope — $\frac{9}{16}$ " (14.29 m) dia. Type "N"; 6 x 25 (6 x 19 class) filler wire extra improved plow steel, preformed, independent wire rope core, right lay, regular lay.

GENERAL INFORMATION ONLY

This document is for reference only! You must obtain your specific load chart from the crane manufacturer.
 Available Maximum Line Pull^① — Developed by machinery with first layer of wire rope, not based on wire rope strength.

Single Speed Rear Main and Auxiliary Front Drums		
	Pounds	Kilograms
Standard Speed	9,810	4 450

Optional Two-Speed Rear Main Drum		
	Pounds	Kilograms
Standard Speed	9,810	4 450
High Speed	5,510	2 499

Permissible Line Speed and Pull^① — Based on 9/16" (14.29 mm) dia. Type "N" wire rope strength.

Layers of Wire Rope	Drum Speed	Single Speed Hoist				Optional Two-Speed Hoist			
		Rear Main ^② & Auxiliary Front ^② Drums				Rear Main ^② Drum			
		Line Speed		Line Pull		Line Speed		Line Speed	
		F.P.M.	Meters/min.	Pounds	Kilograms	F.p.m.	Meters/min.	Pounds	Kilograms
First	Standard	171	52.12	8,920	4 046	161	49.07	8,920	4 046
	High	—	—	—	—	287	87.48	5,010	2 273
Fifth	Standard	233	71.02	6,570	2 980	218	66.45	6,570	2 980
	High	—	—	—	—	390	118.87	3,690	1 674

- ① Based on GM 4-53 diesel engine.
- ② Drum capable of spooling 6 layers of wire rope, but 6th layer not recommended for lifting.

GENERAL INFORMATION ONLY

We are constantly improving our products and therefore reserve the right to change designs and specifications.

FMC Corporation Crane and Excavator Division World Headquarters Cedar Rapids Iowa 52406
 Cedar Rapids Iowa (2) • Lexington & Bowling Green Kentucky • Ontario Canada • Milan Italy • Queretaro Mexico & Nagoya Japan (under license)

