

Specifications

Hydraulic Lattice Boom Crawler Crane

LS-218H

100-Ton (90 metric ton)

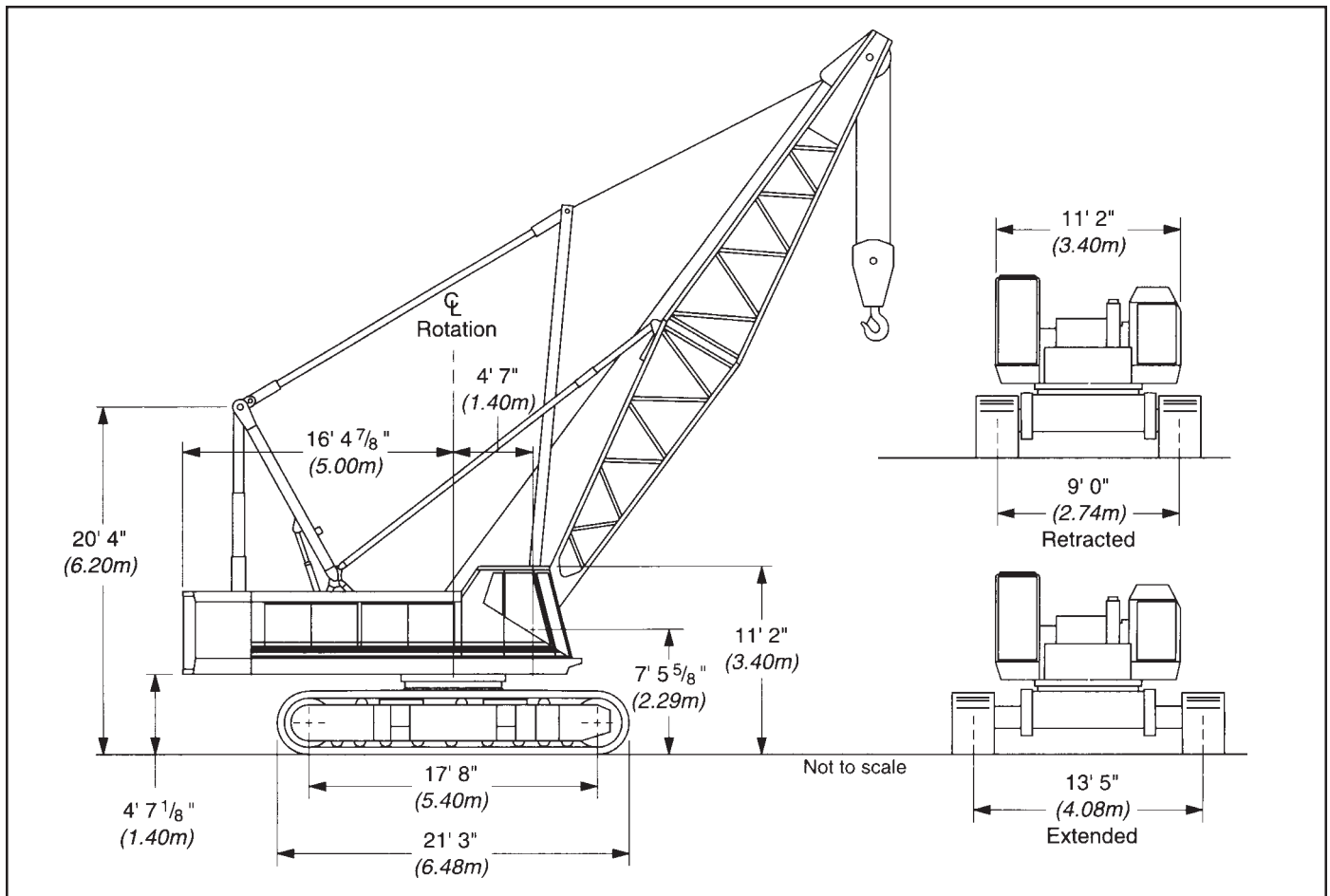

General dimensions	Feet	meters
Basic boom length	40' 0"	12.20
Overall width side frames extended - 36" (.91 m) track shoes	16' 5"	5.00
Overall width side frames retracted - 36" (.91 m) track shoes	12' 0"	3.66
Minimum ground clearance	21"	0.53

General dimensions	Feet	meters
Ground clearance - cwt. "A"	4' 7-1/8"	1.40
Ground clearance - cwt. "AB"	4' 7-1/8"	1.40
Overall width of counterweight	11' 1-3/8"	3.40
Tailswing of counterweight "A"	15' 7-3/8"	4.76
Tailswing of counterweight "AB"	16' 4-7/8"	5.00
Overall width less catwalks	11' 2"	3.40
Overall height for transport, gantry lowered	11' 2"	3.40

LS-218H Machine Transport Weights - approximate

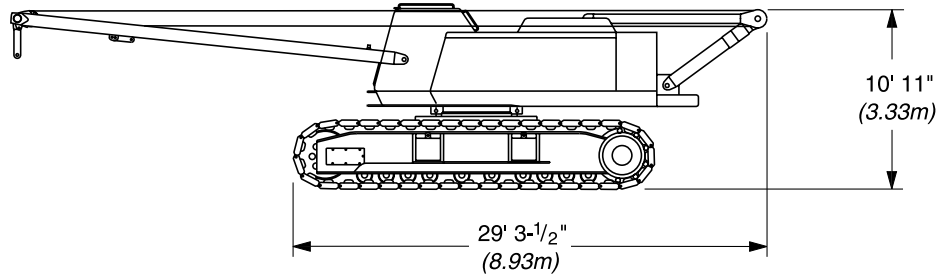
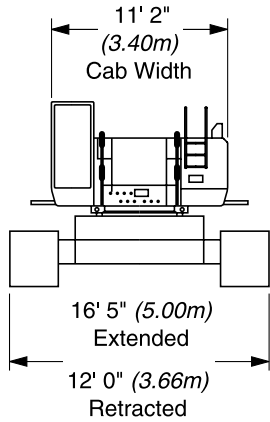

Assembly Weight - as shown
117,560 lbs. (53 325 kg)

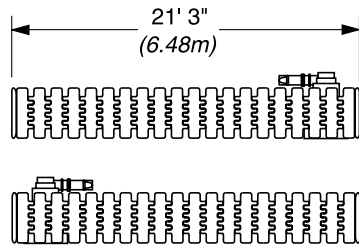

Tread Member w/36" (.91m) Shoes
23,800 lbs. (10 796 kg) Each

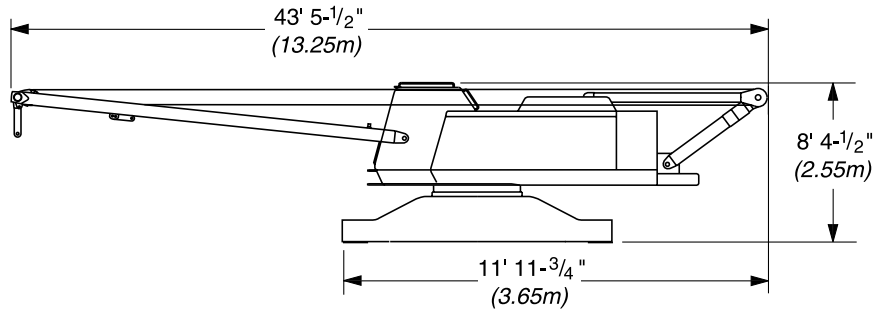

Upper & Carbody Shipping Weight
69,930 lbs. (31 720 kg)



Front Mount Third Drum
1,850 lbs. (839 kg) w/Rope



"A" Upper Counterweight
24,200 lbs. (10 977 kg)



"B" Upper Counterweight
22,500 lbs. (10 206 kg)

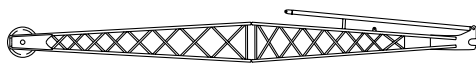
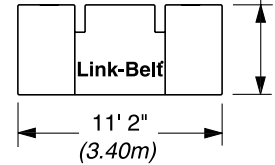

20' (6.10m) Basic Jib Assembly
1,340 lbs. (608 kg) Tube Jib

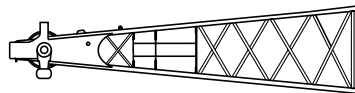

20' (6.10m) Peak Section
3,240 lbs. (1 470 kg) Tube Boom
3,090 lbs. (1 402 kg) Angle Boom

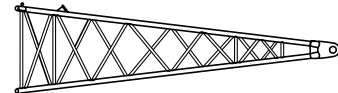

20' (6.10m) Base Section
2,170 lbs. (984 kg) Tube Boom
2,360 lbs. (1 070 kg) Angle Boom

Optional Boom Sections	Weight	Cross Section Size
10' (3.05 m) tube boom extension	770 lbs. (349 kg)	60" (1.52 m) wide x 50" (1.27 m) deep
20' (6.10 m) tube boom extension	1,270 lbs. (576 kg)	60" (1.52 m) wide x 50" (1.27 m) deep
30' (9.14 m) tube boom extension	1,750 lbs. (794 kg)	60" (1.52 m) wide x 50" (1.27 m) deep
10' (3.05 m) angle boom extension	1,040 lbs. (472 kg)	48" (1.22 m) wide x 48" (1.22 m) deep
20' (6.10 m) angle boom extension	1,680 lbs. (762 kg)	48" (1.22 m) wide x 48" (1.22 m) deep
30' (9.14 m) angle boom extension	2,400 lbs. (1 089 kg)	48" (1.22 m) wide x 48" (1.22 m) deep

Machine Working Weight - approximate

Complete basic machine with Mitsubishi 6D24-TEB diesel engine, turntable bearing, hydraulic independent swing and travel, 36" (0.91 m) track shoes, main operating drums and boomhoist, 40' (12.19 m) tubular boom w/live mast, no bucket or hook block but with 900' (274.3 m) of 1" (25 mm) dia. hoist rope.

With 46,700 lb. (21 183 kg) counterweight "AB"

169,650 lbs. (76 953 kg)

Performance Specifications - Wire rope and rope drum data

Main load hoist wire rope length - using 1" (25 mm) diameter wire rope

Parts of line	Boom lengths													
	40' (12.19 m)		50' (15.24 m)		60' (18.29 m)		70' (21.34 m)		80' (24.38 m)		90' (27.43 m)		100' (30.48 m)	
	Feet	meters	Feet	meters	Feet	meters	Feet	meters	Feet	meters	Feet	meters	Feet	meters
1	105	32.00	125	38.10	145	44.20	165	50.29	185	56.39	205	62.48	225	68.58
2	150	45.72	180	54.86	210	64.01	240	73.15	270	82.30	300	91.44	330	100.58
3	195	59.44	235	71.63	275	83.82	315	96.01	355	108.20	395	120.40	435	132.59
4	240	73.15	290	88.39	340	103.63	390	118.87	440	134.11	490	149.35	540	164.59
5	285	86.87	345	105.16	405	123.44	465	141.73	525	160.02	585	178.31	645	196.60
6	330	100.58	400	121.92	470	143.26	540	164.59	610	185.93	680	207.26	750	228.60
7	375	114.30	455	138.68	535	163.07	615	187.45	695	211.84	775	236.22	855	260.60
8	420	128.02	510	155.45	600	182.88	690	210.03	780	237.74	870	265.18	960	292.61
9	465	141.73	565	172.21	665	202.69	765	233.17	865	263.65	965	294.13		
10	510	155.45	620	188.98	730	222.50	840	256.03	950	289.56				

Parts of line	Boom lengths															
	110' (33.53 m)		120' (38.58 m)		130' (39.62 m)		140' (42.67 m)		150' (45.72 m)		160' (48.77 m)		180' (54.86 m)		200' (60.96 m)	
	Feet	meters	Feet	meters	Feet	meters	Feet	meters	Feet	meters	Feet	meters	Feet	meters	Feet	meters
1	245	74.68	265	80.77	285	86.87	305	92.96	325	99.06	345	105.16	385	117.35	420	128.02
2	360	109.73	390	118.87	420	128.02	450	137.16	480	146.30	510	155.45	570	173.74	630	192.02
3	475	144.78	515	156.97	555	169.16	595	181.36	635	193.55	675	205.74	755	230.12	840	256.03
4	590	179.83	640	195.07	690	210.31	740	225.55	790	247.79	840	256.03	940	286.51	1,050	320.04
5	705	214.88	765	233.17	825	251.46	885	269.75	945	288.04						
6	820	249.94	890	271.27												
7	935	284.99														

Clamshell wire rope lengths - using one part of line

Attachment	Function	Boom Lengths									
		40' (12.12 m)		50' (15.24 m)		60' (18.29 m)		70' (21.34 m)		80' (24.38 m)	
		Feet	meters	Feet	meters	Feet	meters	Feet	meters	Feet	meters
Clamshell	Holding	110	33.53	130	39.62	150	45.72	170	51.82	190	57.91
	Closing	160	48.77	180	54.86	200	60.96	220	67.06	240	73.16

Drum wire rope capacities:

Wire rope layer	Front or rear drum - 21-1/2" (0.54 m) root diameter grooved lagging, 1" (25 mm) wire rope				Front mounted third drum - 12-3/4" (0.32 m) root diameter smooth lagging, 5/8" (16 mm) wire rope				Boomhoist drum - 16-1/2" (0.41 m) root diameter grooved lagging, 3/4" (19 mm) wire rope			
	Rope per layer		Total wire rope		Rope per layer		Total wire rope		Rope per layer		Total wire rope	
	Feet	meters	Feet	meters	Feet	meters	Feet	meters	Feet	meters	Feet	meters
1	138	42.18	138	42.18	72	21.9	72	21.9	56	17.24	56	17.24
2	149	45.52	287	87.70	80	24.4	153	46.6	60	18.57	117	35.81
3	160	48.85	448	136.55	88	26.8	242	73.8	65	19.90	182	55.71
4	171	52.19	619	188.74	96	29.3	339	103.3	69	21.23	252	76.94
5	182	55.51	801	244.25	104	31.7	444	135.3	74	22.56	326	99.50
6	193	58.85	994	303.10	113	34.4	557	169.8	78	23.89	404	123.39
7	204	62.18	1,198	365.28					82	25.22	487	148.61
8	214	65.51	1,413	430.79								

LS-218H Load Hoisting Performance

Available line speed and line pull - based on Mitsubishi 6D24-TEB at 2,000 rpm full load speed.

Line pulls are not based on wire rope strength. See wire rope chart for maximum permissible single part of line working loads.

Rope Layer	21-1/2" (.55 m) Front or Rear Drum					12-3/4" (.32 m) Third Drum - Front Mounted			
	speed	fpm	m/min	pounds	kilograms	fpm	m/min	pounds	kilograms
1	Low	102	31.1	54,012	24 500	212	64.6	15,015	6 811
	High	204	62.3	26,340	11 947				
2	Low	110	33.4	49,603	22 500	236	71.9	13,513	6 129
	High	220	67.1	24,190	10 972				
3	Low	117	35.8	45,855	20 800	260	79.2	12,285	5 572
	High	236	71.9	22,360	10 142				
4	Low	125	38.2	42,769	19 400	283	86.3	11,261	5 108
	High	252	76.7	20,850	9 457				
5	Low	133	40.6	39,903	18 100	307	93.6	10,395	4 715
	High	267	81.5	19,460	8 826				
6	Low	141	43.0	37,478	17 000	331	100.9	9,652	4 378
	High	283	86.3	18,270	8 287				
7	Low	149	45.4	35,273	16 000	--	--	--	--
	High	299	91.1	17,200	7 801				
8	Low	157	47.8	33,289	15 100	--	--	--	--
	High	315	95.9	16,230	7 361				

Wire rope: size, type and working strength

Wire rope application	Size: diameter		Type	Maximum permissible load	
	inches	mm		pounds	kilograms
Main Hoist	1	25	N	29,500	13 381
Auxiliary Hoist	1	25	N	29,500	13 381
Boomhoist	3/4	19	W	11,700	5 307
Third Drum	5/8	16	RB	12,900	5 851
Boom Pendants	1-3/8	35	N	n/a	n/a
Jib Pendants	3/4	19	N	n/a	n/a

Wire rope: types available

- Type "RB" – 18 x 19 rotation resistance, extra extra improved plow steel, preformed, right lay, regular lay, swaged.
- Type "N" – 6 X 25 (6 X 19 class), filler wire, extra improved plow steel, preformed, independent wire rope center, right lay, regular lay.
- Type "W" – 6 X 26 (6 X 19 class), extra improved plow steel, preformed, independent wire rope center, right lay, alternate lay.

Crawler Lower

Lower frame

All welded, box construction, precision machined; 13' 5" (4.08 m) extended or 9' 0" (2.74 m) retracted gauge X 21' 3" (6.48 m) track length.

Turntable bearing

Outer race is bolted to upper frame, inner race with internal ring gear is bolted to lower frame.

Crawler side frames

All welded, precision machined and removable; hydraulically extended or retracted by a cylinder mounted inside the lower frame.

Track drive sprockets and idler wheels

Cast steel, heat treated; sealed for lifetime lubrication.

Track rollers

Nine per side. Tractor type, oil filled for lifetime lubrication.

Track carrier rollers

Three tractor type rollers mounted on top of each crawler side frame. Oil filled for lifetime lubrication.

Tracks

Heat treated, self cleaning, multiple hinged track shoes joined by one piece full floating pins; 46 shoes per side frame; 36" (.91 m) wide.

Track tension adjustment - Track adjusted by hydraulic cylinders at the idler block.

Tracks automatically release during excessive tension condition.

Independent travel & steering

Axial piston motor with reduction gear is located at inner drive end of each crawler side frame. Each track is driven simultaneously or individually for straight-line, gradual turn, or pivot turn. The tracks can be counterrotated for spin turns.

Brakes - Spring applied, hydraulically released multiple disc brakes are applied automatically when the control lever is in the neutral position.

Travel speed - 0.8 mph (1.3 km/h)

Gradeability - 30%

Jacking system

Four ground controlled, power hydraulic jacks, mounted on the lower carbody frame, raise the machine to facilitate removal or installation of the crawler sideframes.

Note: Counterweights must be removed prior to machine jacking.

Ground bearing pressure

Track shoes		Ground contact areas		Ground bearing pressure	
inches	meters	in ²	cm ²	psi	kg/cm ²
36	0.91	16,300	105,180	10.41	.73

Revolving Upperstructure

Frame

All-welded, precision machined unit.

Fuel tank

119 gallon (450 L) capacity.

Power transmission

All functions hydraulically powered allowing positive, precise control, with independent or simultaneous operation of all crane functions.

Engine Specifications

Mitsubishi 6D24-TEB with oil filter, oil cooler, air cleaner, fuel filter, water separator, hour meter, tachometer and electrical shutdown.

Number of cylinders	6
Bore and stroke - inch - (mm)	5.12" X 5.91" (130 X 150)
Piston displacement - (in ³) - (cm ³)	729 (11 945)
Engine rpm at full load speed	2,000
Net engine horsepower at full load speed, (HP)	263 (196 kw)
Peak torque - foot pounds - (joule)	746 1 011
Peak torque - rpm	1,400
Electrical system	24 volt
Batteries	2 - 12 volt

Hydraulic System

Hydraulic pumps

Two variable displacement piston pumps operating at 4,000 psi (281 kg/cm^2) power travel, main drum, auxiliary drum, third drum and boomhoist functions. One fixed displacement gear pump operating at 3,000 psi (211 kg/cm^2) powers swing. One fixed displacement gear pump operating at 3,600 psi (250 kg/cm^2) powers jacking cylinders or swing. One fixed displacement gear pump operating at 1,200 psi (85 kg/cm^2) powers pilot control system, clutches, brakes and pump controls.

Hydraulic reservoir

79 US gallon (300 L), equipped with sight level gauge.

Relief valves

Each function is equipped with relief valves to protect the circuit from overload or shock.

Brake valves

Travel circuit is provided with brake valves for all terrain travel capability.

Hydraulic filtration

Ten micron, full flow line filter furnished in control circuit. All oil is filtered prior to return to sump tank.

Hydraulic motors

Main, auxiliary and third hoist drums, boom hoist, swing and travel are powered by axial piston motors.

Counterbalance valves

Hoist motors are equipped with counterbalance valves to provide positive load lowering and prevent accidental load drop when hydraulic power is suddenly reduced.

Principal Operating Functions

Control system

Remote controlled hydraulic servo for main drum, auxiliary drum, third drum and travel. Mechanical linkage controls swing. Function speed is proportional to lever movement. Levers are adjustable for operator comfort.

Load hoisting and lowering

Main and auxiliary hoist drums are driven by individual axial piston motors and reduction gearing. Load hoisting or lowering is provided by actuating or reversing a hydraulic motor. Smooth, precise, power load lowering is attained with automatic hydraulic brake. The control lever provides two speeds for hoisting and lowering. Hoisting or lowering speeds are proportional to lever movement.

Freefall - The incorporation of power hydraulic controlled, two shoe clutches allows freefall operation of the main and auxiliary hoist drums for high cycle crane and duty cycle application. Mode selection switch on control panel allows operator to select the most productive operation mode.

Load hoist drums

Main (front) and auxiliary (rear) hoist drums are 21-1/2" (.55 m) root diameter grooved for 1" (25 mm) wire rope and mounted on anti-friction bearings.

Third operating drum

Optional; Pinned to front of main frame, 12-3/4" (.32 m) root diameter. Hydraulic winch type power up and down standard.

Optional; Same as third drum above but with controlled free spooling for use in pile driving applications.

Drum clutches

Speed-o-Matic® power hydraulic two-shoe clutches; internal expanding, lined shoes. Clutch spiders are splined to shafts; clutch drums are integral with hoist drums.

Load hoist clutches - Front and rear main drums - clutch drums 37" (.94 m) diameter, 5-1/2" (140 mm) face width. Swept area is 638 square inches (4 116 cm²).

Drum brakes

External contracting band type; operated by foot pedal equipped with a locking latch. Operator may select automatic brake mode (spring applied, hydraulically released), which will apply brakes when the hoist control lever is in the neutral position.

Drum rotation indicators

Standard for front and rear drums. Audible-type indicators.

Drum locking pawl

Standard for front and rear drums; electrically actuated and prevents drum rotation in a lowering direction.

Load indicator

Standard: PAT EI-65 load indicator for main drum. See Auxiliary Equipment on page 8 for description and other available load indicators.

Anti two-block system

Standard: A switch mounted on the boom peak activates a buzzer to warn the operator of a two-block condition and simultaneously disengages hoist function while applying the hoist brakes.

Swing system

Independent, hydraulic swing is driven by two axial piston motors through a gear reduction system.

Swing brake - Spring applied, hydraulically released; controlled by button on swing control lever.

Swing lock - Mechanically controlled, drop pin.

Swing speed - Two-speed, 1.3 / 2.5 rpm

Boomhoist/lowering system

Independent, hydraulic boomhoist is driven by an axial piston motor through a gear reduction system. Boom hoisting or lowering is performed by actuating or reversing the motor.

Boomhoist drum

Single grooved lagging 16-1/2" (.42 m) root diameter.

Boomhoist drum locking pawl

Electrically operated.

Boomhoist brake

Spring applied, hydraulically released, multiple disc type brake. Brake is automatically applied when control lever is in neutral position.

Boomhoist limiting device - Restricts hoisting boom beyond recommended minimum radius.

Electrical system

24 volt negative ground system, with two 12-volt batteries. Standard lighting system includes: two 70 watt headlights mounted on machine front and one interior cab light.

Operator's cab

Full vision, modular compartment with safety glass panels. The completely independent cab is insulated against noise and vibration. Sliding operator's door, swing up roof window. Standard equipment includes: heater, defroster, windshield wiper, dry chemical fire extinguisher, sun visor, bubble-type level, fuel gauge, tachometer, hydraulic temperature gauge, engine oil pressure gauge, coolant temperature gauge, service monitor system, and EI-65 load indicator system.

Machinery cab

Hinged doors (four on right side, three on left side) for machinery access. Equipped with rooftop access ladder and electric warning horn.

Catwalks

Standard on both sides. Catwalks fold up for reduced travel width.

Gantry

Retractable high gantry is power lowered to reduce height for transport. May also be used for power raising or lowering of counterweight.

Gantry bail

Pinned to retractable high gantry. Four sheaves are provided for 10-part boomhoist wire rope reeving. Sheaves mounted on anti-friction bearings, sealed for lifetime lubrication.

Counterweight

Removable, held in position by bolts. Standard counterweight lowering system consists of retractable high gantry and hydraulic cylinders.

Counterweight "A" - 24,200 lbs. (10 977 kg)

Counterweight "B" - optional - 22,500 lbs. (10 206 kg) Required for maximum lift crane capacities.

Booms and Jibs

Booms

Angle - Two piece basic boom 40' (12.19 m) long with open throat top section. Boom 48" (1.22 m) wide, 48" (1.22 m) deep at centerline of connections. Main chord angles are high strength, low alloy steel, 4" x 4" x 3/8" (101.6 mm x 101.6 mm x 9.53 mm).

Base section - 20' (6.10 m) long. Boom feet on 61" (1.55 m) centers. Lifting lugs on top side of base section to attach carrying links for boom assembly.

Boom extensions - Available in 10', 20', and 30' (3.05 m, 6.10 m, and 9.14 m) lengths with appropriate length pendants.

Boom connections - In-line tapered pin.

Boom top section - Open throat, 20' (6.10 m) long.

Boompoint machinery - Four 18" (.46 m) root diameter head sheaves mounted on anti-friction bearings with rope and sheave guards standard for lift crane use.

Tubular - Two piece basic boom 40' (12.19 m) long with open throat top section. Boom 60" (1.52 m) wide, 50" (1.27 m) deep at centerline of connections. Alloy steel, round tubular chords 3" (76 mm) outside diameter.

Base section - 20' (6.10 m) long. Boomfeet on 61" (1.55 m) centers. Lifting lugs on top side of base section to attach carrying links for boom assembly.

Boom extensions - "H" wall chord. Available in 10', 20', and 30' (3.05 m, 6.10 m, and 9.14 m) lengths with appropriate length pendants.

Boom connections - In-line tapered pins.

Boom top section - Open throat; 20' (6.10 m) long.

Boompoint machinery - Five 21" (.53 m) root diameter head sheaves mounted on anti-friction bearings. Rope and sheave guards are standard.

Tubular jib

Tubular - basic two-piece 30' (9.14 m) long, 32" (.81 m) wide and 24" (.61 m) deep at connections. Alloy steel tubular chords 2" (51 mm) outside diameter. Offsettable 0, 15, or 30 degrees relative to main boom angle.

Base section - 15' (4.57 m) long.

Jib extensions - available in 15' (4.57 m) lengths with appropriate length pendants.

Jib connections - In-line, tapered pin connections.

Tip section - 15' (4.57 m) long, one 18-1/2" (.47 m) root diameter sheave mounted on anti-friction bearings.

Jib mast

11' 6" (3.51 m) high, mounted on jib base section. Two deflector sheaves mounted within mast to guide whipline; mounted on anti-friction bearings. Two equalizer sheaves mounted on top of mast - one for jib frontstay line, one for jib backstay line.

Jib staylines - Front and rear staylines vary in length depending on degree of jib offset from boom center line; backstay lines attached at bottom end of boom top section.

Jib stops - Dual, tubular telescoping type.

■ Boom stops

Dual, tubular telescoping type.

■ Boom live mast

26' (7.92 m) long rectangular structure which supports boomhoist bridle, boom pendants and midpoint suspension pendants. Boom live mast may be used as a short crane boom for machine assembly or dismantling. Standard with tubular boom attachment; *optional* for angle boom attachment.

■ Boomhoist bridle and spreader bar

Serves as connection for boom suspension system. Bridle contains five 12" (.30 m) root diameter sheaves mounted on anti-friction bearings for 10-part boomhoist wire rope reeving. Auxiliary bail may be attached to bridle and contains two 15-7/8" (.40 m) root diameter bronze bushed sheaves to permit reeving wire rope suspension for use of boom live mast as short boom. Spreader bar provides attachment for boom main pendants and boom midpoint suspension pendants.

■ Deflector rollers

Deflector rollers deflect main and auxiliary load hoist wire rope over top side of boom. Rollers are mounted on anti-friction bearings. One roller on top section of basic boom and one roller per boom extension is standard for both angle and tube booms.

Auxiliary Equipment

■ Boom angle indicator

Pendulum type, mounted on operator's side of boom base section.

■ Load indicator

The **standard** PAT EI-65 load indicator for the main drum provides the operator with: main boom length, main boom angle, jib angle, jib length, operating mode, load radius, boom tip height, and anti-two block indicator.

Optional; PAT EI-65 load indicator for auxiliary drum. (Additional line rider required.)

Rated Capacity Limiters (*Optional*)

Optional; PAT DS-350 rated capacity limiter for main and auxiliary drums. (Additional line rider required for auxiliary drum.)

The optional rated capacity limiter system (RCL) provides the same information as the load indicator plus the crane's rated capacity at a particular setup with function kickout. Includes a pre-warning light, audible alarm, and overload light.

■ Fairlead

Optional; full revolving type with barrel, sheaves and guide rollers mounted on anti-friction bearings.

■ Tagline

Rud-o-Matic® model 648; spring wound, drum-type.

Link-Belt Construction Equipment Company

A unit of Sumitomo Construction Machinery Co., Ltd.

© Link-Belt is a registered trademark. Copyright 1997. All rights reserved. We are constantly improving our products and therefore reserve the right to change designs and specifications.