

# Specifications

Hydraulic Rough Terrain Crane

## RTC-8020

20-ton (18.16 metric ton)

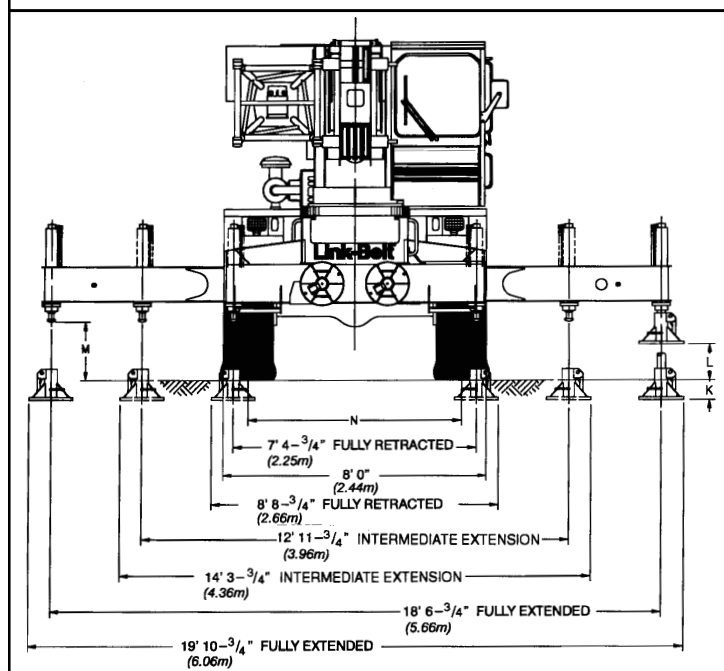
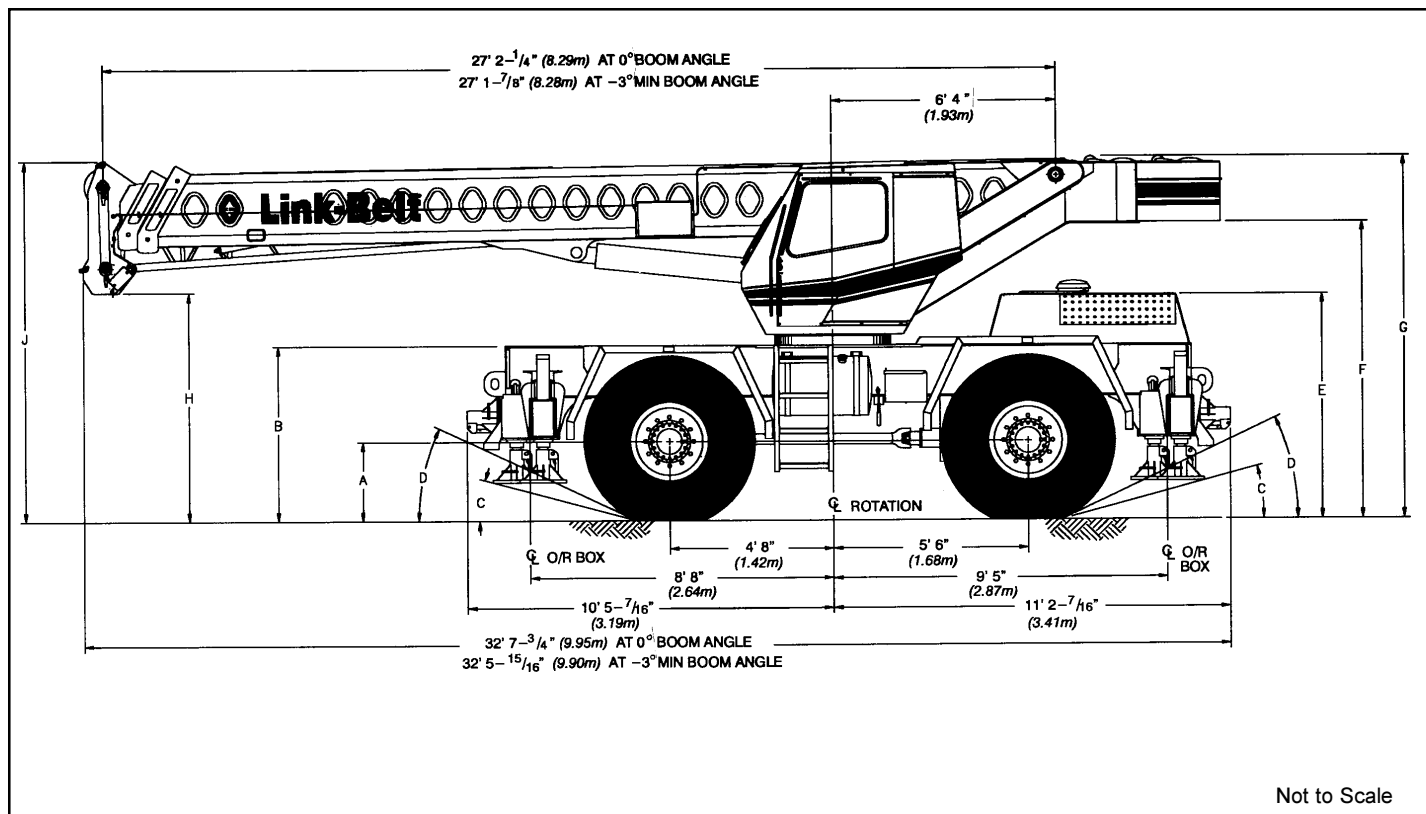

General dimensions	feet	meters
Turning radius (4-wheel steer - centerline of tires)	17' 9"	5.41
Tailswing of counterweight	11' 1"	3.38

### Dimensions affected by tires

Tires	16.0 X 24 (16-PR)		17.5 X 25 (20-PR)	
	feet	meters	feet	meters
A	2' 3-3/8"	.70	2' 1-3/16"	.64
B	5' 1/4"	1.53	4' 10-1/16"	1.47
C	15°	—	12°	—
D	25°	—	22°	—
E	6' 5-1/4"	1.96	6' 3-1/16"	1.91
F	8' 5-3/4"	2.58	8' 3-5/16"	2.53
G	10' 4-1/4"	3.16	10' 2-1/16"	3.10
H	6' 11-1/16"	2.11	6' 8-7/8"	2.05
J	10' 8-3/16"	3.26	10' 6"	3.20
K	7-1/8"	.18	9-5/16"	.24
L	1' 1-3/4"	.35	11-9/16"	.29
M	1' 9-1/2"	.55	1' 7-1/8"	.49
N	6' 5-7/8"	1.98	6' 5-1/8"	1.96

# Upperstructure

## ■ Boom

**Patented Design.** Base and center section side plates have diamond shaped impressions for superior strength to weight ratio and 100,000 p.s.i. (689.5 MPa) steel angle chords for lateral stiffness. The tip section is a formed fabricated box section. Boom telescope sections are supported by wear shoes both vertically and horizontally to prevent metal to metal contact.

**Microguard 414, Rated Capacity Limiter "RCL" - Standard;** Audio-visual warning system with anti-two block and function limiters. Operating data available includes boom length, boom angle, head height, radius of load, machine configuration, allowed load, actual load and percent of allowed load. Presettable alarms for maximum and minimum boom angles, max. tip height, max. boom length, swing left/right positions.

**Standard boom** — 27.12' - 70.12' (8.27 m - 21.37 m) three-section full power, fully synchronized boom.

**Boom head — Standard** — Three 10-5/8" (0.27 m) root diameter head sheaves handle up to 6 parts of wire rope. Two easily removable wire rope guards and rope dead end lugs provided on each side of boom head.

**Auxiliary lifting sheave** — *Optional*; Single 10-5/8" (0.27 m) root diameter sheave with removable wire rope guard, mounted to boom. For use with one or two parts of line off the optional auxiliary winch. Does not affect erection of fly, or use of main head sheaves for multiple reeving.

**Boom elevation** — One Link-Belt designed hydraulic cylinder with holding valve and bronze bushings in each end. Hand control for controlling boom elevation from -3° to + 78°.

## ■ Fly

*Optional* — 25' (7.62 m) fixed stowable one piece lattice type.

*Optional* — 25' (7.62 m) offsettable stowable one-piece lattice type.

*Optional* — 25' - 43' (7.62 m - 13.10 m) offsettable stowable type lattice with telescoping box section.

## ■ Cab and Controls

Environmental cab; isolated from sound with acoustical foam insulation, all tinted and tempered safety glass windows. Sliding rear and right side window and swing up roof window for maximum visibility and ventilation. Slide-by-door opens to 2' 4" (0.71 m) width. 6-way adjustable operator's seat. Hydraulic control levers (joystick style) for swing, winches and boom hoist. Outrigger controls conveniently located on dash; sight level bubble also provided in upper cab. Foot controls for boom telescope, swing brake, travel brake and engine throttle.

**Cab instrumentation** — Cab instrumentation — Dash mounted gauges for hydraulic oil temperature, converter temperature, fuel, water temperature, voltmeter and oil pressure.

## ■ Swing

Bi-directional hydraulic swing motor mounted to a planetary reducer for 360° continuous smooth swing at 2.0 r.p.m.

**Swing parking brake** — Foot operated manually applied/released, disc brake mounted on the speed reducer.

**Swing brake** — Foot operated, spring released disc brake mounted on the speed reducer.

**Swing lock** — Standard; two position travel lock operated from the operator's cab. *Optional* 360° swing lock.

**Counterweight** — Bolted to upperstructure frame.

## ■ Hydraulic System

**Main pump** — Double gear type pump. Combined pump capacity 58 gpm (220 lpm). Driven off rear of transmission. An optional pump disconnect with engine jogging is available. Pump operates at 3,500 p.s.i. (246 kg/cm<sup>2</sup>) maximum system pressure.

**Swing / steering pump** — Single gear-type pump, 17 gpm (64 lpm) maximum. Powered by carrier engine through a straight mechanical drive. Pump operates at 3,000 p.s.i. (211 kg/cm<sup>2</sup>).

The three pump hydraulic circuit allows simultaneous operation of the three main crane functions (winch, boom hoist, swing) without any function interface.

**Reservoir** — 63 gallon (238.46 L) capacity. Single diffuser for deaeration.

**Filtration** — One 10-micron filter located outside hydraulic reservoir. Accessible for easy replacement.

**Control valves** — Five separate control valves allow simultaneous operation of all crane functions.

## ■ Load Hoist System

**Standard** — 1M main winch with single speed motor and automatic brake; power up/down mode of operation with hoist drum cable follower. Bi-directional piston-type hydraulic motor, driven through a double planetary reduction unit for positive operator control under all load conditions.

*Optional* — Model 1M auxiliary winch with one-speed motor and automatic brake, power up/power down mode of operation with hoist drum cable follower.

*Optional* - Winch function lockout on machines equipped with two drums.

**Line pulls and speeds** — Maximum line pull 9,000 lbs. (4,082 kg) and maximum line speed of 282 f.p.m. (84.60 m/min) on standard 10-5/8" (0.27 m) root diameter smooth drum.

## ■ Additional Equipment - Standard

Sound suppressed cab, fire extinguisher, seat belt, warning horn, mirrors, windshield wiper and backup alarm, lifting lugs, audible swing alarm, and automotive style wiring with sealed relays and connectors.

## ■ Additional Upperstructure Equipment - Optional

360° swing lock, propane, diesel or hydraulic heater, electronic drum rotation indicators, 25-ton (22.68 metric ton) hook block, 5-ton (4.54 metric ton) hook ball and swivel, rear steer indicator, engine monitoring system, tachometer, top hatch window wiper, amber rotating beacon, windshield washer, 360° cab mounted spotlight, cab-mounted working lights, and boom flood light.

# Carrier

## ■ Type

8' 0" (2.44 m) wide, 122" (3.10 m) wheelbase.

4 x 4 x 4 — (4-wheel steer, 4-wheel drive)  
**Standard** — For rough terrain with limited turning area.

4 x 4 x 4 — (4-wheel steer, 4-wheel drive)  
*Optional* — Rear axle with no-spin differential; for rough terrain with limited turning area.

**Frame** — 100,000 p.s.i. (689.5 MPa) steel, double walled construction with integral 100,000 p.s.i. (689.5 MPa) steel outrigger boxes.

## ■ Axles

**Front-** Standard; heavy duty planetary drive/steer type.

**Rear-** Standard; heavy duty planetary drive/steer type.

**Rear-** *Optional*; heavy duty no-spin differential, planetary drive/steer type.

## ■ Suspension

**Front axle-** Rigid mounted to frame.

**Rear axle-** Pin-mounted on welded steel box cradle. Automatic hydraulic rear axle oscillation lock-out engages when upperstructure rotates past 2-1/2° of centerline.

## ■ Tires

**Front and Rear Standard** — 16.00 x 24 (16-PR)

*Optional* — 17.5 x 25 (20-PR)

## ■ Brakes

**Service** — Hydraulic, drum-type brakes at each wheel end. Drum diameter 17" (0.43 m). Shoe width 4" (.10 m).

**Parking** — Spring applied, hydraulic released; cab controlled, mounted on front axle.

## ■ Steering

Hydraulic two wheel, four wheel and "crab" steering; controlled from steering wheel.

## ■ Transmission

Clark three-speed two range power shift transmission. Six speeds available forward and six speeds reverse. Engine mounted torque converter.

## ■ Outriggers

Three position (fully extended, intermediate and fully retracted) operation. Four hydraulic, telescoping beam and jack outriggers. Vertical jack cylinders equipped with integral holding valve. Beams extend to a maximum 18' 6-3/4" (5.66 m) centerline-to-centerline and retract to within 8' 0" (2.44 m) overall width. Equipped with stowable, light-weight 16" (0.41 m) diameter steel floats. Controls and sight level bubble located in upperstructure cab.

## ■ Confined Area Lift Capacities (CALC)

**System** - Outriggers may be extended to an intermediate position (12' 11-3/4" - 3.96 m) for working in confined areas. Outrigger box and beam are connected by an extend position pin which allows the outrigger beams to be fully extended or limits them to partially extended length based on the selected pin position. In addition, capacities are available with the beams in the 7' 4-3/4" (2.25 m) fully retracted position.

## ■ Additional Equipment - Standard

Cab steps, 2 front and rear carrier steps, air cleaner service indicator, skid resistant finish on carrier deck, key locking storage, battery box and engine compartment, automatic front axle disconnect, fenders, carrier mounted travel lights, automotive type wiring with sealed relays and connectors, throttle lock, hour meter, and towing lugs.

## ■ Additional Equipment - Optional

No-spin differential on rear axle, front and rear towing shackles, 110 volt engine block heater, ether injection package, dual battery system, spare tires and rims, rear mounted pintle hook, manual pump disconnect with engine jogging switch, auxiliary steering system, and recessed carrier mounted winch.

## Travel speeds and gradeability

Engine	Tires	Maximum Speed		*Gradeability at stall	Maximum tractive effort at stall		Gradeability at 1.0 mph (1.61 km/h)	Maximum tractive effort at 1.0 mph (1.61 km/h)	
		mph	km/h		pounds	kg		pounds	kg
Cummins 4BT 3.9	16.0 X 24	24.3	39.10	141%	33,462	15,178	49%	18,410	8,351
	17.5 X 25	22.5	36.20	211%	36,954	16,762	56%	20,331	9,222

\*Transmission lubrication must not exceed 47% grade.

### Engine Specifications

Engine	Cummins 4BT 3.9
Cylinders - cycle	4 - 4
Bore	4.02" (102.1 mm)
Stroke	4.72" (119.9 mm)
Displacement	239.2 cu. in. (3 920 cm <sup>3</sup> )
Maximum brake hp	110 @ 2500 rpm
Peak torque	293 ft. lbs. (397 J)
Electric system	12 volt negative ground
Fuel capacity	40 gallons (151.4 L)
Alternator	100 amps
Crankcase capacity	11.6 qts. (10.98 L)

### Axle loads

Base machine with standard 27.12' — 70.12' (8.27 m - 21.37 m) three-section boom, 350' (106.68 m) 5/8" (16 mm) wire rope, 4 x 4 x 4 carrier with Cummins 4BT 3.9 engine, 16.0 X 24.0 tires, full fuel and counterweight.	G.V.W. <sup>①</sup>		Upper facing front				Upper facing rear			
			Front axle		Rear axle		Front axle		Rear axle	
	lbs.	kg	lbs.	kg	lbs.	kg	lbs.	kg	lbs.	kg
	37,328	16 932	18,018	8 173	19,310	8 759	18,631	8 451	18,697	8 481
17.5 x 25.0 tires	-56	-26	-28	-13	-28	-13	-28	-13	-28	-13
Hookblock at boom head	430	195	1,112	504	-682	-309	-647	-293	1,077	488
Headache ball at boom head	189	86	489	222	-300	-136	-284	-129	473	214
Auxiliary lifting sheave	114	52	306	139	-192	-87	-182	-82	296	134
25' (7.62 m) lattice fly stowed	533	242	692	314	-159	-72	-116	-52	649	294
25' (7.62 m) offsettable lattice fly stowed	975	442	1,299	589	-324	-147	-244	-111	1,219	553
25' - 43' (7.62 m-13.1 m) offsettable lattice fly stowed	1,520	689	1,987	901	-467	-212	-342	-155	1,862	844

① Adjust gross vehicle weight & axle loading according to component weight.

**Note:** All weights are ± 3%

Tire	Max. Axle Load @ 20 mph (32.7 km/hr)
16.00 x 24 (16-PR)	25,000 lbs. (11 340 kg)
17.50 x 25 (20-PR)	25,000 lbs. (11 340 kg)

**Link-Belt Construction Equipment Company** Lexington, Kentucky

A unit of Sumitomo Construction Machinery Co., Ltd.

® Link-Belt is a registered trademark. Copyright 1997.

We are constantly improving our products and therefore reserve the right to change designs and specifications.